

**LXXXI.** *A Description of Two Methods, by which the Irregularity of the Motion of a Clock, arising from the Influence of Heat and Cold upon the Rod of the Pendulum, may be prevented; by John Ellicott, F. R. S.*

Read June 4, 1752. **T**HE first of these methods consists in a particular construction of the pendulum itself, which occur'd to me several years ago. In the beginning of the year 1738, I put into the hands of Mr. Machin, then one of the secretaries, a description and a drawing of such a pendulum, in order to their being laid before this honourable Society: but Mr. Machin, soon after, acquainting me, that a gentleman, of whose skill and judgment in mechanical contrivances I had always entertain'd the highest opinion, made some objections, I was advis'd to defer communicating my invention to this Society, till I should have examined into the weight of those objections, and, by a fair and impartial trial, should be fully assur'd, that the contrivance would answer the end propos'd. And having now at length obtain'd that satisfaction, I beg leave to give a short narrative of some of the most remarkable observations I have made during this inquiry, which I hope will not prove unacceptable to this honourable Society.

About the year 1732, an experiment, which I made, in order to satisfy some gentlemen, that the rod of a pendulum was liable to be considerably influenced by moderate degrees of heat and cold, led me

me to consider, that, as metals differ from each other in their density, it was highly probable they might likewise differ from each other in their expansion; and that this difference of the expansions of two metals might be so applied, as in a great measure to remove those irregularities in the motion of a clock, which arise from the effect of heat and cold upon the length of a pendulum. With this view, not long afterwards I contrived the pendulum now described by Fig. 1.

In which *ab* represents a bar of brass, made quite fast at the upper part by pins, and held contiguous, at several equal distances, by the screws 1, 2, 3, &c. to the rod of the pendulum, which is a bar of iron; and so far as the brass bar reaches, is filed of the same size and shape, and consequently does not appear in the figure; but a little below the end of the brass bar, the iron is left broader, as at *dd*, for the conveniency of fixing the work to it, and is made of a sufficient length to pass quite thro' the ball of the pendulum to *c*. The holes, 1, 2, &c. in the brass, thro' which the shanks of the screws pass into the iron rod of the pendulum, are filed as in the drawing, of a length sufficient to suffer the brass to contract and dilate freely by heat and cold under the heads of the screws. *eeee* represents the ball of the pendulum: *ff*, two strong pieces of steel, or levers, whose inner centres, or pivots, turn in two holes drilled in the broad part of the pendulum-rod, and their outer ones in a strong bridge, or cock, screw'd upon the same part of the rod, but omitted in the draught; because, when put on, it covers this mechanism. *gg*, are two screws entering at the edge,  
and

Fig. 1.  
p. 480.

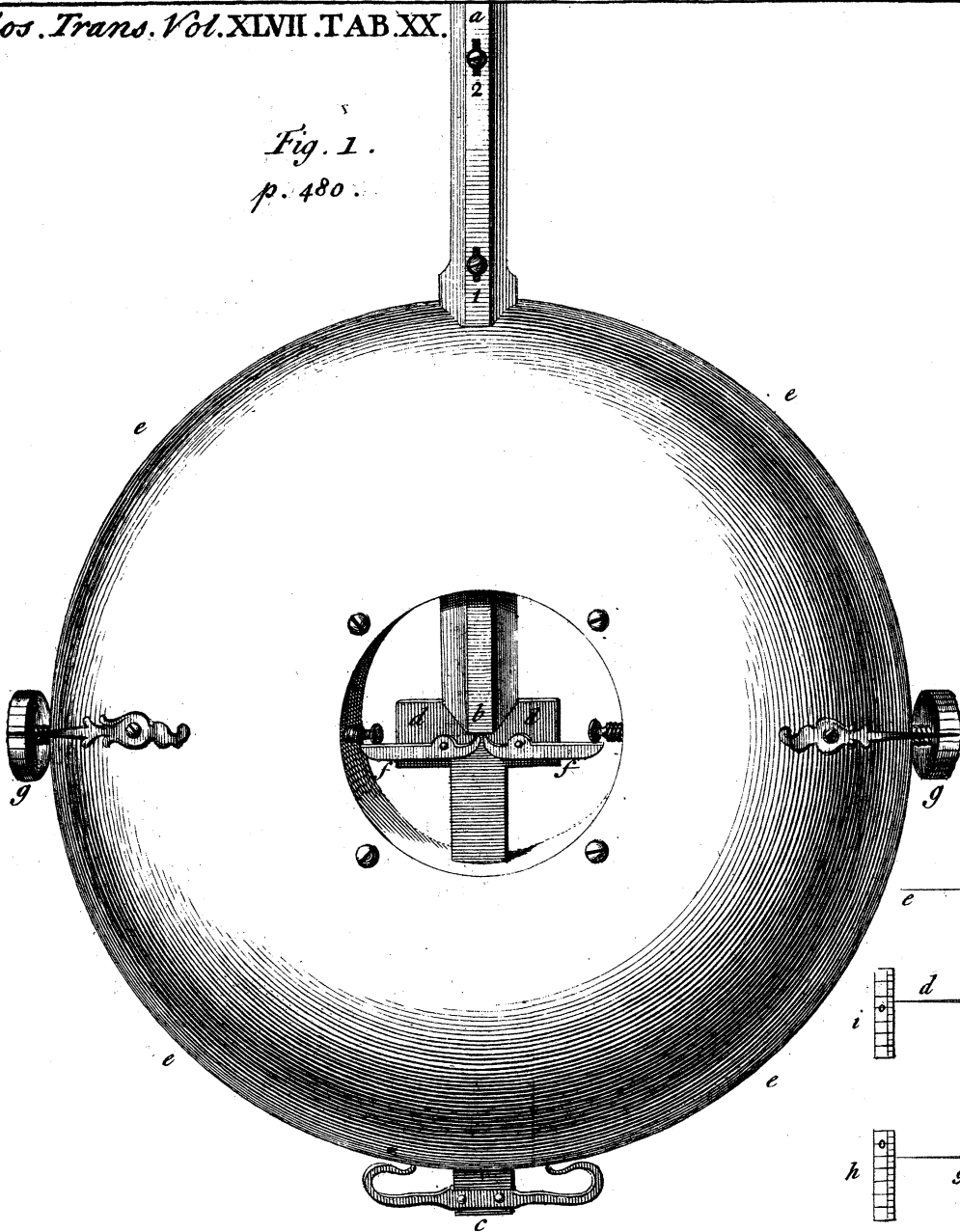

Fig.  
p. 481.

Fig. 2. p. 481.

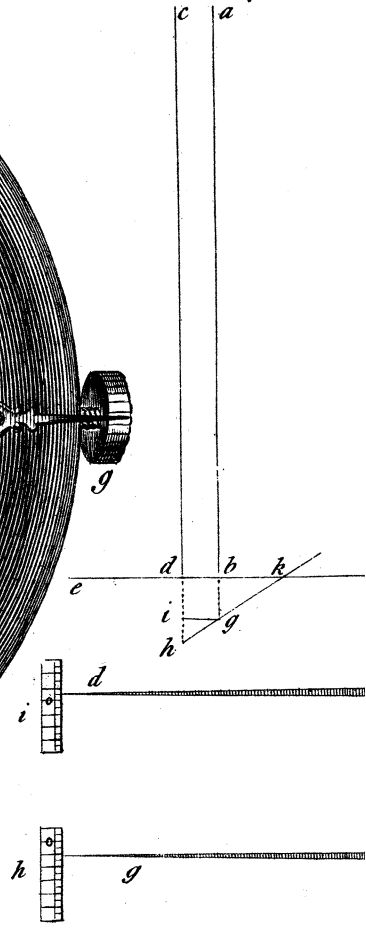
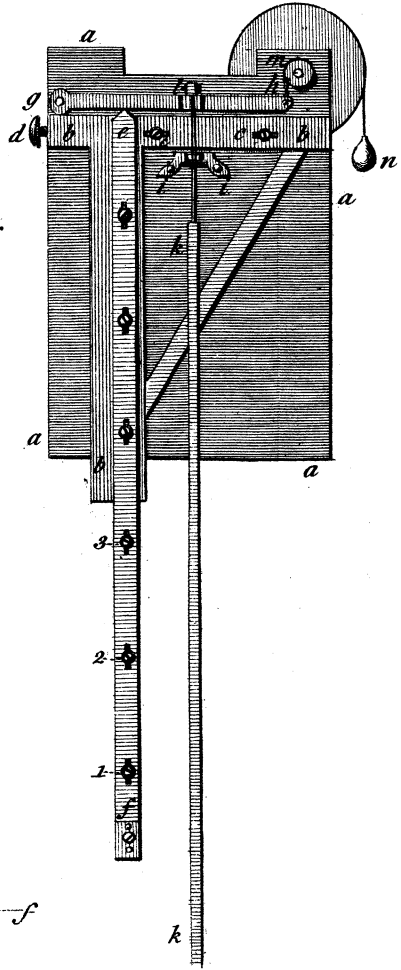
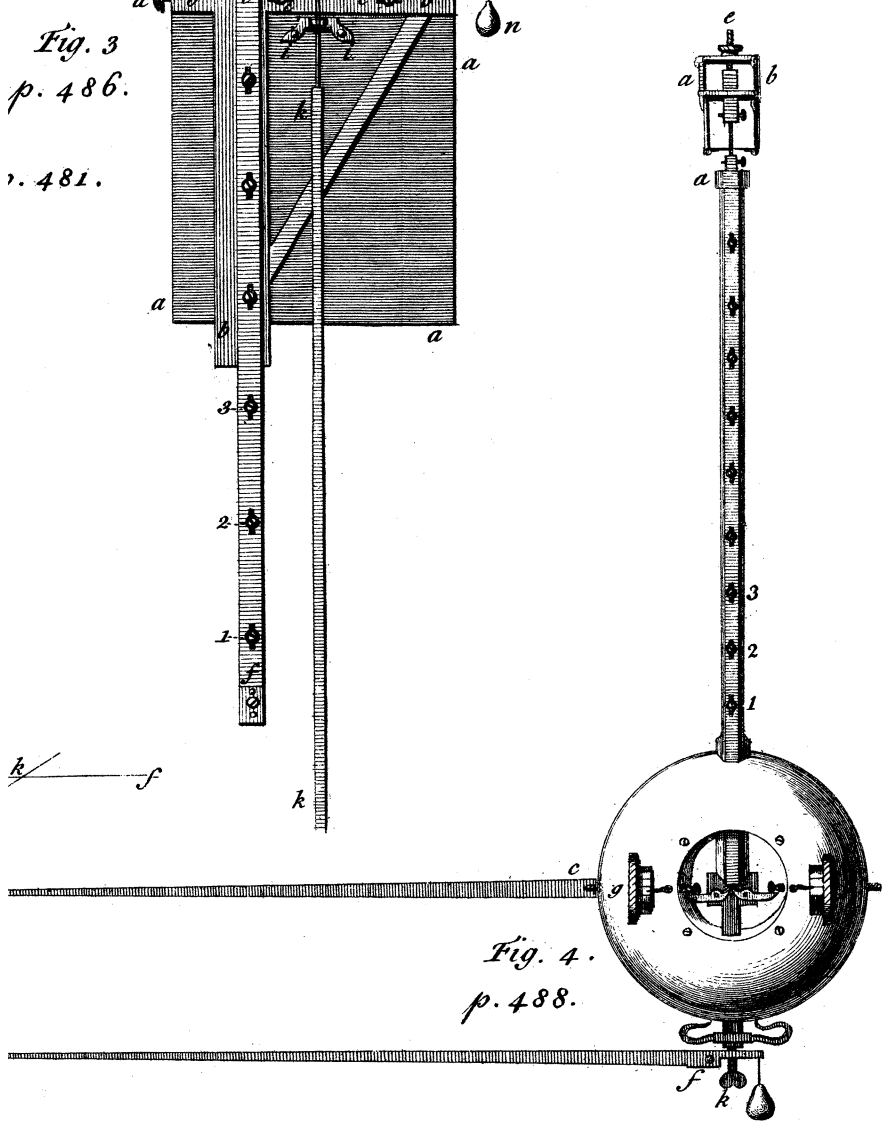

Fig. 3  
p. 486.  
1. 481.



$\frac{k}{f}$

Fig. 4.  
p. 488.



J. Mynde sc.

and reaching into the cavity near the centre of the ball. The ends of these screws next the centre are turn'd into the form represented in the drawing, which, pressing with the weight of the ball against the longer arms of the levers, cause the shorter arms to press against the end of the brass bar at  $c$ . Things being in this situation, let us suppose, that the rod of the pendulum, and the brass annexed to it, grow longer by heat; and that the brass lengthens more than the iron of the same length: then the brass, by its excess of dilatation, will press the short ends of the levers downwards at  $c$ , and at the same time necessarily lift up the ball, which rests upon the long ends of the same levers at  $ff$ , to any proportion necessary: And provided the ends of the screws do press upon the levers at a proper distance from the centres, the said ball will be always kept at the point of suspension, notwithstanding any alteration the rod of the pendulum may be liable to from heat or cold. What this distance ought to be, may very nearly be determined, if the difference of the expansion between the brass and iron bars is known; for the proportion the shorter arms of the levers ought to bear to the longer ones will always be, as the excess of the expansion of the brass is to the whole expansion of the iron, as may be thus easily demonstrated. Fig. 2.

Let the line  $ab$ , drawn perpendicular to the line  $ef$ , represent a bar of iron; the line  $cd$  a bar of brass, the pricked line  $bg$ , the expansion of the brass bar by the same degree of heat: let the line  $gi$  be drawn parallel to the line  $ef$ , then will  $ib$  represent the difference of the expansion of the two metals: thro' the points  $b, g$ , draw a right line  
P p p
cutting

cutting the line  $ef$ , as in  $k$ ; this line may be supposed to represent one of the levers turning upon its centre at  $g$ ,  $b$  the point where the brass bar acts upon the shorter end of the lever, and  $k$  the point where the screw acts upon the longer end of the lever, which being the place where it intersects the line  $ef$ , it is evident the ball of the pendulum will be as much raised by the lever, as it would have been depressed by the expansion of the iron; but the triangle  $ibg$  is similar to the triangle  $bgk$ ; and therefore, as  $ib$ , the excess of the expansion of the brass, is to  $bg$ , the whole expansion of the iron, so will  $bg$ , the shorter arm of the lever, be to  $gk$ , the longer arm of the lever. Q. e. d.

At Fig. 1. is placed a strong double spring, whose ends pressing against the under edge of the ball, hinder it from bending the brass bar by its forcible action thereon at the point  $b$ , which, when the ball is of a considerable weight, it might otherwise be very liable to do.

The description here given is exactly agreeable to the original contrivance; and the only alteration I have since made in it, consists in placing the screws  $gg$  within the ball of the pendulum, as represented in Fig. 4.

But as the success of this contrivance depended intirely upon the supposition, that metals were expanded differently by the same degree of heat, before I attempted to put it in execution, I thought proper to inquire what experiments had already been made upon this subject, when Mr. John Eames, a late very worthy member of this Society, put into my hands Mr. Graham's account of his quicksilver pendulum

pendulum (as it is now commonly called) published in the *Philosophical Transactions*, N<sup>o</sup> 392, which account I found to be introduced by the following paragraph :

“ Whereas several, who have been curious in measuring of time, have taken notice, that the vibrations of a pendulum are slower in summer than in winter ; and have very justly supposed this alteration has proceeded from a change of length in the pendulum itself, by the influences of heat and cold upon it, in the different seasons of the year ; with a view therefore of correcting, in some degree, this defect of the pendulum, I made several trials, about the year 1715, to discover whether there was any considerable difference of expansion between brass, steel, iron, copper, silver, &c. when exposed to the same degrees of heat, as nearly as I could determine ; conceiving it would not be very difficult, by making use of two sorts of metals differing considerably in their degrees of expansion and contraction, to remedy, in great measure, the irregularities, to which common pendulums are subject. But although it is easily discoverable, that all these metals suffer a sensible alteration of their dimension by heat and cold ; yet I found their differences in quantity, from one another, were so small, as gave me no hopes of succeeding this way, and made me leave off prosecuting this affair any farther at that time.”

The reading this paragraph proved at that time sufficient to make me lay aside all thoughts of succeeding in a contrivance founded upon principles, which a gentleman of so great abilities, and known

accuracy in making experiments, had, after trial, judged to be insufficient. And it was not till about the latter end of the year 1734, that I again resumed them on the following occasion. A gentleman desirous to make some experiments concerning the expansion of metals, employ'd me to make him an instrument like one invented by Mr. Muschenbroek for that purpose, which he calls a pyrometer. Upon looking over Mr. Muschenbroek's experiments, I not only found the difference between the expansion of some of the metals much greater than I expected, but, as I thought (if they were to be depended upon) sufficient to answer my former purpose. This led me to consider the structure of the instrument, which Mr. Muschenbroek made use of in his trials, and upon examination, I thought it liable to some objections, which I imagined would make the result of experiments made by his instrument very uncertain. I therefore endeavour'd to contrive one of a different construction, that might be more to be depended upon. Such an instrument I some time afterwards completed, and had the pleasure to find it so far met with the approbation of several very worthy members of this Society, that, at their particular desire, I drew up a description of it, which was read, and the instrument itself shewn to the Society on the 8 of April 1736\* : and though it was not in every respect

---

\* This appears from the minutes of the Royal Society ; tho' the description and manner of that instrument was, by some mistake, placed six months later in the *Philos. Transf. Vol. XXXIX. N. 443.* for October 1736. The other dates, mention'd in this paper, relating to that instrument, are likewise justified by authentic vouchers, which have been produced by Mr. Ellicott.



spect so accurate as I could wish, I am fully persuaded, that such experiments, as are carefully made with it, may be depended upon, as very near the truth. Having made a great variety of experiments with this instrument upon bars of different metals, as nearly of the same dimensions as possible, I found, upon a medium, their several expansions by the same degree of heat to be as follows :

Gold	Silver	Brafs	Copper	Iron	Steel	Lead
73	103	95	89	60	56	149

And as I found so great a difference between the expansion of brafs and iron, I immediately determined to make a pendulum after the manner above described, composed of those two metals, and likewise order'd a clock to be made, with the utmost care and exactness; and, as I then apprehended, with some considerable improvements, with which I intended to make the experiments. These were both finished in the beginning of the year 1738; and having no reason to doubt of success, I shew'd the pendulum to the late Mr. Machin, and gave him a drawing and description of it, in order to its being communicated to the Royal Society; but, as I have already observed, objections were made to it, of which the only one, that appeared to have any weight, was, that it had been found by experiment, that two bars of different metals, screw'd together, so as to be in contact with each other, would not expand regularly and smoothly, but by jerks. In order to examine into the force of this objection, I directed two bars of equal dimensions to be made, one of brafs, the other of iron, of about two feet in length, fasten'd together after the same manner, as the two rods of the pendulum,

pendulum, which I intended to place so, that, by acting very near the centre of an index of a considerable length, even the smallest alteration in the bars would be made sensible, and by the motion of the index I should be able to form a judgment, whether the rods moved regularly and freely, or not : but before this was put into execution, I contrived, by fastening the two bars to the back plate of a clock, not only to make them answer the end above propos'd, but, at the same time, to lengthen or shorten a pendulum of a common construction, in such a manner, as sufficiently to correct the irregularities arising from the influence of cold or heat upon it. The manner of applying them is described by Fig. 3.

In which, *aaaa* represents the back plate of the clock, *bbb*, a triangular piece of brass, screw'd by two screws, thro' the slits *cc*, to the plate, yet so that it may be drawn backwards or forwards by means of the screw at *d*. *ef* is a brass bar, about two feet in length, made fast at the bottom, by a screw and two pins at *f*, to an iron one of equal dimensions, to which it is likewise screw'd by the screws 1, 2, 3, &c. after the same manner as the rod of the pendulum already described. The iron bar is fastened at the upper end to the triangular piece of brass, nearly under that part of the brass bar marked *e*. *gb* is a strong brass or iron lever, moveable upon a centre at *g*, and is supported by the upper end of the brass bar ; *ii* is the cock, on which, in a common clock, the pendulum is hung ; *kk*, part of the rod of the pendulum, whose spring passing thro' a fine slit in the cock *ii*, is fasten'd to a stud riveted into the lever at *l*. The slit in the cock  
muff.

must be made so close, as to prevent the spring from having any lateral motion in it.

From this description it is evident, that, if the brass bar expands more than the iron one, it will raise up the lever, and, consequently, the pendulum, which is fasten'd to it; and, as the length of the pendulum is only from the centre of oscillation to the under part of the slit, thro' which the spring passes, the pendulum will be thereby shortened; and, by making the point of the brass bar to act upon a proper part of the lever (to which it is capable of being adjusted by means of the screw *d*) the pendulum may be shortened to whatever degree shall be necessary.

To prevent the pendulum from bending the bars, which it would be liable to do, if the ball of the pendulum was of any considerable weight, the end of the lever, farthest from its centre of motion, is hook'd to the end of a chain, which is wound about and fastened to a small pulley at *m*. Upon the same arbor, to which this pulley is fixed, is fastened another pulley, of a much larger diameter, to which is hung, by a silk line, the weight or counterpoise *n*. By means of this counterpoise, any part of the weight of the pendulum, that shall be desired, may be taken off from pressing against the brass bar. And if, upon the end of the arbor, to which the pullies are fixed, an index be placed, so as to point to a graduated circle, the least motion of the lever will not only be easily perceived, but also whether that motion is uniform and regular, or not. And upon having, some time after, made a clock with this contrivance added to it, I had the pleasure to find the index not only to move very sensibly, but very regularly, and never,  
that

that I could perceive, by jerks. And I doubt not, but, when the point of bearing of the brass bar upon the lever is once well adjusted, it will be found to lengthen or shorten the pendulum to as great a degree of exactness, as any other method whatsoever. But, as I have not as yet thought of any other method of adjusting it, except from actual trial in different seasons of the year, I must prefer the pendulum to this method, which, from the great ease, as well as exactness, with which it is capable of being adjusted, will, I think, appear to have much the advantage over any other contrivance yet made use of for this purpose.

The method I take for adjusting the longer arms of the levers of the pendulum to the shorter ones is described in Fig. 4. To a strong post, fixed to the wall, is fastened a small shelf, supported by two brackets *a b*. In the middle of this shelf is fastened a wire, by the screw *e*; to the end of which the pendulum is to be hung. Below this shelf, at the distance of about 40 inches, is placed the index *c d*, turning freely upon a center: The length of the index is 50 inches. At the distance of half an inch, upon a part of the index produced beyond the centre, is placed a steel pin; and in the back of the pendulum, as near the centre of oscillation as may be, is drilled an hole to receive this pin; when the pendulum is hung upon the wire against the post, and the wire is screw'd higher or lower by the screw *e*, till the pin resting against the upper part of the hole (which is filed into a proper shape for that purpose) keeps the index nearly in an horizontal position. Below the bottom of the pendulum is placed a second index

index *fg*, exactly like the former, except that it is kept in an horizontal position, by the screw *k* bearing against the end of the iron rod. When the experiment is to be made, the pendulum is first put into a box, and gradually heated by a large fire, to a considerable degree, being often turned, that every part may be equally exposed to the fire. And having continued shut up in the box for some time after it is removed from the fire, that the two rods may be heated as uniformly to the same degree as possible, the pendulum is hung upon the wire, and the two indexes made to stand nearly in an horizontal position. The two graduated plates *bi* are then slid upon a wire, till the divisions in each mark'd *o* are pointed to by the indexes. As the pendulum cools, the lower index will be seen gradually to descend; but if the ends of the two screws, in the ball of the pendulum, act upon proper parts of the levers, the upper index will continue in the same place. If the ends of the screws are either too far off, or too near the centres of the levers, the index will either rise or descend; and, by comparing the number of divisions it has varied, with those which the lower index has varied, a near estimate may be made, how much the screws require to be alter'd; and, in a very few trials, they may easily be adjusted to a very great exactness. In order to make an actual trial, how far this contrivance of the pendulum will answer the end proposed, it is necessary, that the clock, to which the pendulum is fitted, be made with great exactness, and intirely to be depended on: For otherwise the experiments will be very uncertain, as I found in the clock I first made use of.

I have already observed, that, in order to render this clock as perfect as possible, I made it, in several respects, different from the common ones, in hopes of removing some imperfections I apprehended they were liable to. But as, in this attempt, I fell into an error, which it was a considerable time before I discover'd, my making the trial was thereby greatly retarded. And in order to prevent others from falling into the like mistake, I shall beg leave to give some short account of it.

In a common clock the pendulum is usually hung by a spring to a cock on the back plate of the clock, whilst the wheel and pallets, by which the pendulum is kept in motion, are placed in the middle of the frame; and the pendulum is moved by a piece of steel (call'd the crutch) riveted to one end of the arbor, to which the pallets are fastened. This disposition of the pieces I apprehended liable to some considerable objections: To remedy which, I contrived to fix the pallets to the upper part of the pendulum itself, above the centre of motion; and, in order to make the pendulum vibrate as freely as possible, it was made to turn upon two steel points, and was hung in the middle of the frame, exactly under the swing-wheel, and so as to vibrate in the same plane with it. By this means I was in hopes, that it would have moved with much greater freedom and regularity, than when hung after the common method; and, upon trial, it was found to move with so great freedom, that a pendulum of above 20 pounds weight, when hung in its place without the clockwork, and made to vibrate thro' an arch of two degrees, was found to make above

1200 vibrations, before it had lost half a degree, and was observed to have a sensible motion above 20 hours afterwards; and the clock, when first put together, was kept going, for several days, by a weight of only eleven ounces, hung to the end of a single line. But it was not long, before I discover'd, that this great freedom made it liable to be considerably affected by the least motion.

A remarkable instance of this I communicated to this Society, which was published in the *Philosophical Transactions*, N<sup>o</sup> 453. But the greatest objection to this method was, the points being subject to wear; and I found, that the least alteration in them would occasion the clock to vary much more, than (without having made the trial) I could have imagined. To remedy this inconvenience, I made the pendulum to move upon edges, like those, on which the beam of a pair of scales turns (a method I had good reason to believe had been made use of with success); but I found these likewise liable to wear, tho' not in so short a time as the points; so that, after much time spent in making several experiments, in order to remedy this inconvenience, I found myself obliged to lay this method wholly aside, and to hang the pendulum upon a spring, as usual.

In making this alteration, I observed one circumstance, which I think deserves to be taken notice of. Before I made any alteration in the work, I took particular notice to what height the pendulum required to be raised, before the pallets would escape from the wheel. I next observed the number of degrees of each vibration of the pendulum, when mov'd by the clockwork; and then, the clockwork being remov'd,

the pendulum was made to describe an arch of two degrees ; and particular notice was likewise taken, in what space of time it had lost half a degree each vibration. Having then made the necessary alterations for hanging the pendulum by a spring, and particular care being taken that the pallets should scape off from the wheel exactly at the same angle as before, the pendulum being hung by its spring, and made to vibrate thro' an arch of two degrees, it was observed to lose half a degree in about half the time it did when turning upon edges. But, upon being set a-going by the clock-work, the pendulum was found to describe an arch of near two degrees more than before : For, when it turned upon the edges, it described an arch of only three degrees ; whereas, now it was hung by the spring, it vibrated near five degrees ; which was very different from what I expected.

This alteration being made, I soon found, that the clock went very regular ; and, after a sufficient trial, was fully satisfied the pendulum would answer my expectations. But, fearing lest I might be thought prejudiced in favour of my own invention, I engaged the Rev. Mr. Professor Bliss to make trial of it ; and, accordingly, in the beginning of the year 1750, I sent to him, at Oxford, a clock for that purpose ; and, in January last, I received from him a letter, giving his opinion of it, of which the following (so far as relates to the clock) is an exact copy.

“ S I R,

“ I have now had thorough trial of the clock ;  
 “ and am perfectly satisfied, that your pendulum  
 “ takes



“ takes off the effect of heat and cold as well as  
 “ either the gridiron-pendulum (as it is com-  
 “ monly called) or the quicksilver pendulum; and  
 “ this upon sufficient trial for near two years. It has  
 “ this advantage of both the fore-mention’d ones,  
 “ that it may, by lengthening or shortening the  
 “ levers, be easily adjusted to the exact proportion  
 “ of the difference of the iron and brass, which nei-  
 “ ther of those kinds is capable of, without very  
 “ great trouble and difficulty. I was indeed preju-  
 “ diced against the method of doing it by levers, as  
 “ I had heard the late Mr. Graham say, that he had  
 “ tried levers in different ways, that he found they  
 “ did not work regularly and freely, but by jerks.  
 “ However, in your method, I am satisfied, by the  
 “ fullest experience, that they succeed as well as  
 “ either of the other forts, or perhaps any other kind,  
 “ that may be invented hereafter.”

Before I conclude this paper, I shall beg leave  
 to acquaint this honourable Society, that, in the  
 year 1748, I made a model of a contrivance to be  
 added to a pocket-watch, founded upon the same  
 principles, and intended to answer the like pur-  
 pose, as the pendulum above described. And, at  
 a meeting of a council of this Society, on February  
 15 last, I produced a watch (which I had made for  
 a gentleman) with this contrivance added to it, and  
 likewise the model, by which was shewn to the  
 gentlemen then present what effect a small degree of  
 heat would have upon it. But, as I have not yet  
 had sufficient trial of this watch, I shall defer giving  
 a particular description of this contrivance, till I am  
 fully

fully satisfied to what degree of exactness it can be made to answer the end proposed, I am,

Gentlemen,

June 4, 1752.

Your most obedient

humble servant,

J. Ellicott.

LXXXII. *A Description of a new Tackle or Combination of Pullies, by Mr. J. Smeaton,*

Read June 11, 1752. **T**HE axis in *peritrochio*, and the compound pulley, are the only mechanic powers, which can with convenience be applied to the moving large weights, when the height, to which they are intended to be raised, is considerable. The excellence of the former is, their working with little friction; that of the latter, in their being easy to be moved from place to place, and applied *extempore*, as occasion requires.

The present methods of arranging pullies in their blocks may be reduced to two. The first consists in placing them one by the side of another upon the same pin; the other in placing them directly under one another, upon separate pins. But in each of these methods an inconvenience arises, if above 3 pullies are framed in one block. For, according to the first method, if above 3 pullies are placed by the side of one another, as the last line, by which the draught

Fig. 1.  
p. 480.

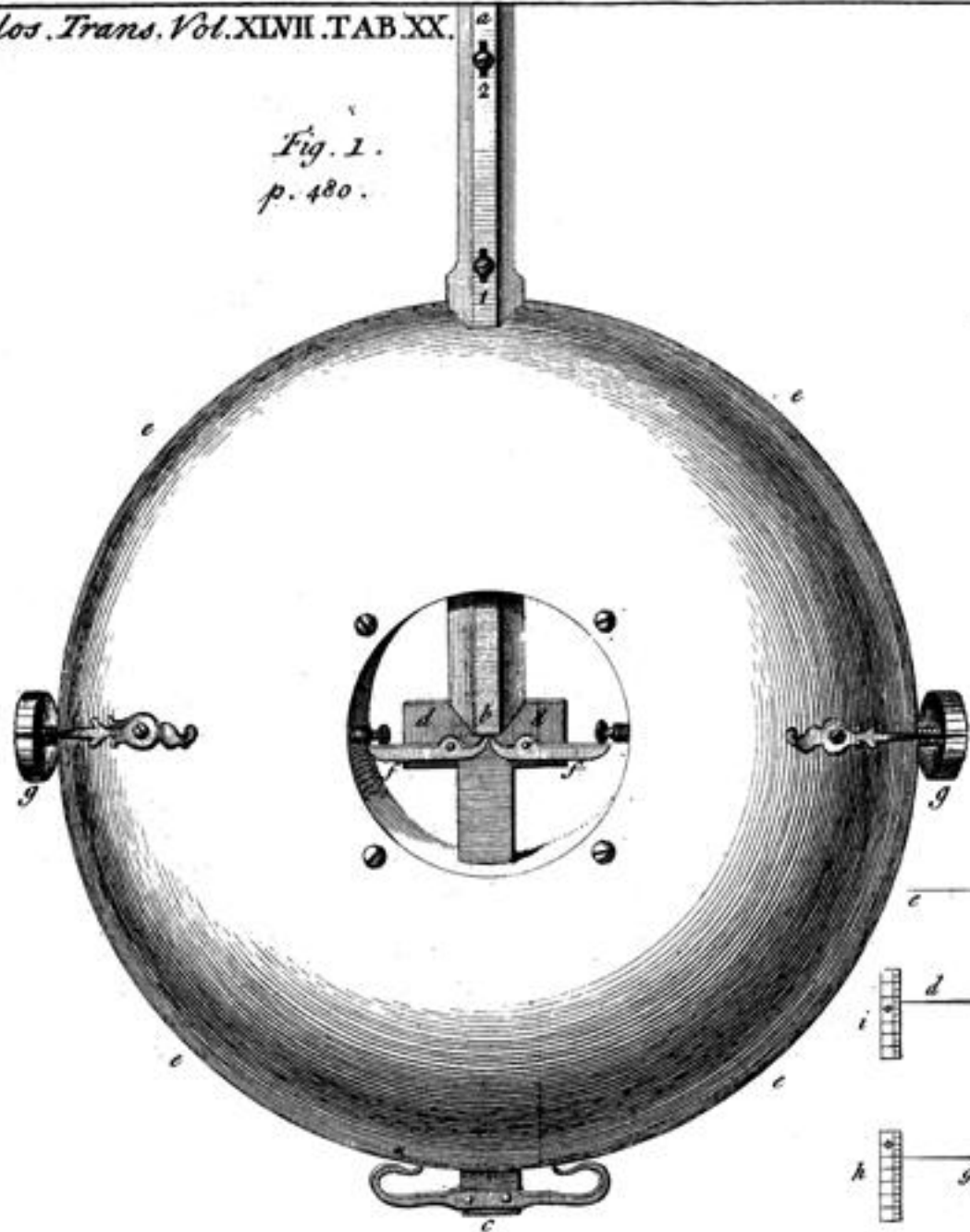

Fig. 3.  
p. 486.

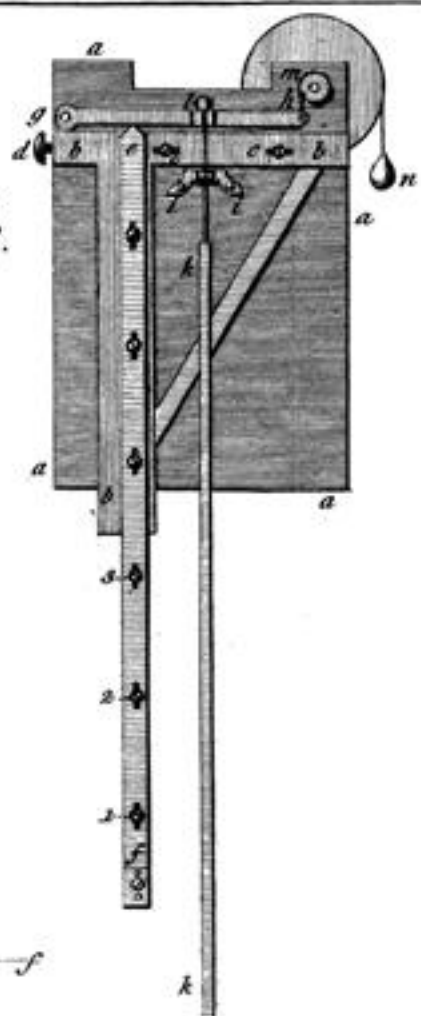

Fig. 2. p. 481.

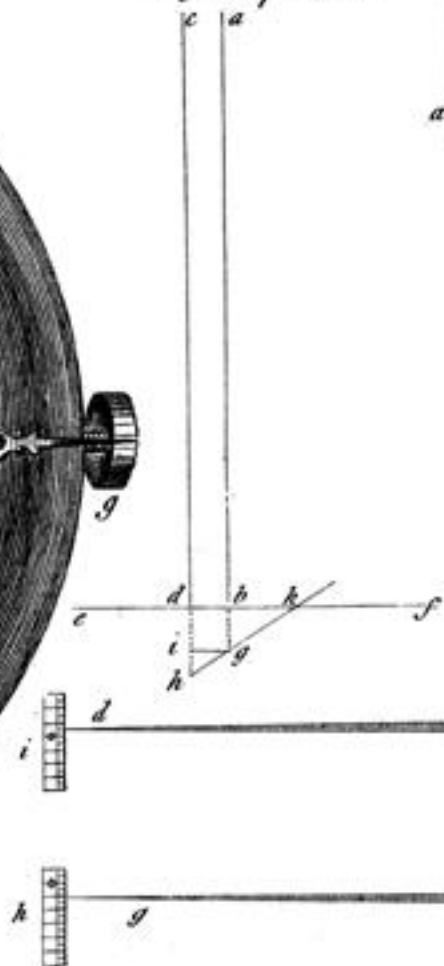

Fig. 4.  
p. 488.

